

Directed[®] AUDIO

OWNER'S MANUAL



model | **6500**

CONGRATULATIONS

Congratulations for choosing a Directed Audio five-band parametric equalizer from Directed Electronics.

Directed has been the industry leader in high-quality mobile audio and security since 1990, and with the introduction of the Directed Audio 6500 five-band parametric equalizer, Directed continues to set new standards of performance, reliability and affordability in the mobile electronics industry.

Featuring separately adjustable front and rear crossovers, active gain pream-

plifiers and three-source input capability, the Directed Audio 6500 five-band parametric equalizer will integrate with the most sophisticated of mobile audio/video systems, and will excite and delight the mobile sound enthusiast with years of high-quality audio reproduction.

The Directed Audio 6500 five-band parametric equalizer is covered by two-year limited warranty. Be sure to retain your original sales receipt, and refer to the warranty section of this guide for full details about your coverage.

TABLE OF CONTENTS

Limited Two-Year Consumer Warranty	4
Features	5
Warning	5
Installation Guidelines	6
Control Panel Features	7
Rear Panel Features	9
Initial Settings	10
Crossover and Filter Adjustments	11
System Diagram	12
Specifications	13

LIMITED TWO-YEAR CONSUMER WARRANTY

Directed Electronics, Inc. promises to the original purchaser, to replace this product should it prove to be defective in workmanship or material under normal use, for a period of two years from the date of purchase by the dealer as indicated by the date code marking of the product **PROVIDED** the product was installed by an authorized Directed dealer. During this two-year period, there will be no charge for this replacement **PROVIDED** the unit is returned to Directed, shipping pre-paid. If the unit is installed by anyone other than an authorized Directed dealer, the warranty period will be one year from the date of purchase by the dealer as indicated by the date code marking of the product. During this one-year period there will be no charge for this replacement **PROVIDED** the unit is returned to Directed, shipping pre-paid. This warranty is non-transferable and does not apply to any unit that has been modified or used in a manner contrary to its intended purpose, and does not cover damage to the unit caused by installation or removal of the unit. This warranty is void if the product has been damaged by accident or unreasonable use, neglect, improper service or other causes not arising out of defects in materials or construction. **ALL WARRANTIES INCLUDING BUT NOT LIMITED TO EXPRESS WARRANTY, IMPLIED WARRANTY, WARRANTY OF MERCHANTABILITY, FITNESS FOR PARTICULAR PURPOSE, AND WARRANTY OF NON-**

INFRINGEMENT OF INTELLECTUAL PROPERTY ARE EXPRESSLY EXCLUDED TO THE MAXIMUM EXTENT ALLOWED BY LAW, AND DIRECTED NEITHER ASSUMES NOR AUTHORIZES ANY PERSON TO ASSUME FOR IT ANY LIABILITY IN CONNECTION WITH THE SALE OF THE PRODUCT. DIRECTED HAS ABSOLUTELY NO LIABILITY FOR ANY AND ALL ACTS OF THIRD PARTIES INCLUDING ITS AUTHORIZED DEALERS OR INSTALLERS. Unit must be returned to Directed, postage pre-paid, with: consumer's name, telephone number, and address, authorized dealer's name and address, and product description. **IN ORDER FOR THIS WARRANTY TO BE VALID, YOUR UNIT MUST BE SHIPPED WITH PROOF OF INSTALLATION BY AN AUTHORIZED DIRECTED DEALER. ALL UNITS RECEIVED BY DIRECTED FOR WARRANTY REPAIR WITHOUT PROOF OF DIRECTED DEALER INSTALLATION WILL BE COVERED BY THE LIMITED ONE-YEAR PARTS AND LABOR WARRANTY.** **Note:** This warranty does not cover labor costs for the removal and reinstallation of the unit. **BY PURCHASING THIS PRODUCT, THE CONSUMER AGREES AND CONSENTS THAT ALL DISPUTES BETWEEN THE CONSUMER AND Directed SHALL BE RESOLVED IN ACCORDANCE WITH CALIFORNIA LAWS IN SAN DIEGO COUNTY, CALIFORNIA.**

FEATURES

- 18dB boost/cut filters with adjustable center frequencies.
- Dual function controls pull out for easy system tuning.
- Separately adjustable front and rear high-pass crossovers.
- Dedicated subwoofer output with adjustable low-pass crossover.
- Front panel controls for fader, sub level, and HP/LP frequencies.
- Master volume control drives over 10 volts RMS output (sub out).
- Three switched inputs for controlling multiple sources.
- Selectable dual color illumination and backlit controls.
- Built-in remote output with turn-on delay for switching on amps.
- 30V MOSFET switching power supply.
- Gold-plated RCA input/output jacks.
- Half-din chassis for ease of installation.

WARNING



High-powered car audio systems may produce sound pressure levels that exceed the threshold at which hearing loss may result.

They may also impair a driver's ability to hear traffic sounds or emergency vehicles. Use common sense and practice safe listening habits when listening to or adjusting your audio system.

INSTALLATION GUIDELINES

1. Read this manual carefully and in its entirety before installing this equalizer.
2. Always disconnect the battery or remove the fuses for circuits you will be working on.
3. Check for clearance of any hazards such as wiring harnesses or heater core before mounting the equalizer to any panels in the vehicle.
4. Mount the equalizer in a location that is easy to access and won't be distracting to vehicle operation while making adjustments.
5. Route all power wires and audio cables away from sharp metal edges that can cause shorts to ground and any moving parts that can tangle the wires such as heater controls or wiper motors.
6. Route all power and signal cables as far as possible from other vehicle wiring harnesses. Loom when appropriate.
7. It is recommended that the equalizer be grounded directly to the chassis of the Source 1 head unit. The Source 1 head unit should be grounded at a chassis point (preferably bare or scraped sheet metal) other than the factory head unit ground wire or under dash brackets.
8. Use only the supplied machine screws to mount the equalizer or damage to the circuitry could occur.

CONTROL PANEL FEATURES

Adjustment Knobs

The 6500 five-band parametric equalizer features dual-function control knobs that extend when needed for adjustments and retract when not in use, allowing full adjustability with minimum control panel clutter. When the knobs are extended for adjustment they have an in and out position that allows each knob to control multiple processor settings.

- **Extend and Retract Knobs** - To extend and retract the adjustment knobs, press and release them into the control panel; they will extend or retract with each press.
- **IN and OUT Position** - A knob is set to its in position when it is initially extended. To set a knob to its out position pull gently on the knob until a plainly-felt notched position is reached.

NOTE: DO NOT use excessive force when using the adjustment knobs or damage to their release mechanism can result.

1. Master Volume/Fader Control Knob

- **IN/VOLUME** - When in this knob controls the overall volume of the system. It affects all line-level outputs to the amplifiers.
- **OUT/FADER** - When out this knob controls the front to rear

balance of the high-pass output jacks.

2. **Input Source LED** - The color of the LED indicates which input source is currently active.

GREEN indicates Source 1 is active.

RED indicates Source 2 is active.

ORANGE indicates the control panel AUX is active.

3. **Input Source Switch** - This is a momentary push-button switch that will cycle through the three input sources by activating a new input source each time it is pressed.

NOTE: The EQ defaults to SRC 1 when the unit is switched on.



4. Subwoofer Volume Control

- **IN/SUB VOLUME:** When in this knob controls the dedicated subwoofer output volume.
- **OUT/SUB FREQUENCY:** When out this knob controls the low-pass crossover frequency for the dedicated subwoofer output between 30-400Hz at 12dB/octave.

5. High-Pass Output Frequency Control

- **IN/FRONT OUT FREQUENCY:**
When in this knob controls the high-pass crossover point for the front outputs between 30Hz and 400 Hz at 12dB/octave.
- **OUT/REAR OUT FREQUENCY:**
When out this knob controls the high pass crossover point for the rear outputs between 30Hz and 400 Hz at 12dB/octave.

NOTE: If rear panel switch #7 is in the full range position this knob has no function.

6. Frequency Controls

- **IN/FREQUENCY GAIN CONTROL:**
When IN these knobs control the gains for their respective frequencies. The center position

is flat with a maximum +18dB and -18dB adjustment capability.

- **OUT/PARAMETER CONTROLS:**
When out these knobs control the center frequency of their respective filter band. The center frequency ranges are described in the chart below.

Control Knob	Filter Parameter
Subwoofer	30 to 70 Hz
Midbass	125 to 250 Hz
Low Midrange	400 to 800 Hz
High Midrange	1 to 5 kHz
High Frequencies	8 to 20 kHz

- Aux In** - This is a 3.5 mm stereo input jack for use as an auxiliary input for portable music players, laptops, camcorders, or video games.

FIGURE 1—CONTROL PANEL

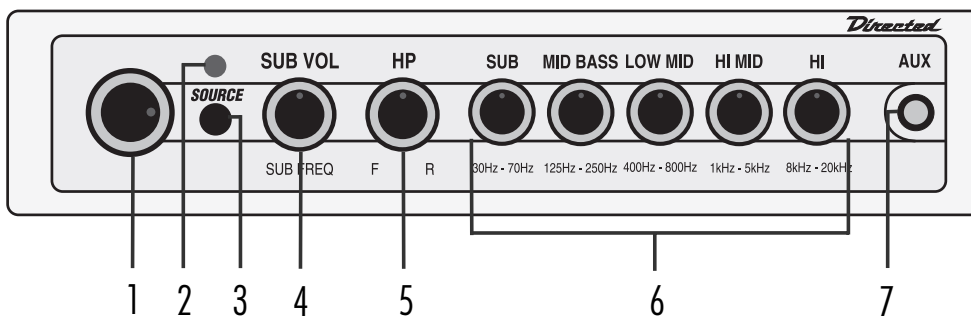

REAR PANEL FEATURES

Power Connector

1. **Remote Turn On Output** - This output is intended to be the remote turn on for the system amplifiers and has a built-in delay. Two to three seconds after the 6500 receives a (+)12V turn on signal it will send a (+)12V turn on signal to the amplifiers. This feature is designed into the 6500 to eliminate system turn-on pops that can occur when several components turn on at the same time.
2. **(+)12V Constant Power** - This is the main power input for the 6500 and must be connected to a (+)12V constant power supply. DO NOT connect this to a switched 12V source or the system may pop when the key is turned off.
3. **Remote Turn On Input** - This is the input for turning on the 6500 and system amplifiers. It should be connected to the (+) 12V remote turn on output of the system head unit. The 6500 has a built in turn off delay to prevent turn-off pops. When the remote turn on signal from the head unit shuts off, the amplifiers will turn off immediately and the 6500 will stay on for five seconds before turning off. This feature is designed into the 6500 to eliminate system turn off pops that can occur when several components turn off at the same time. DO NOT connect this to a (+)12V constant power supply.
4. **Ground** - Connect this terminal to a quality ground location, preferably the chassis of the head unit, which must itself be properly grounded to the vehicle chassis. It is not recommended that the factory radio ground be used for after market audio components.
5. **Power Fuse** - This fuse protects the 6500's on-board electrical components. Never replace this fuse with one of higher value or damage to the 6500 could occur and result in loss of your warranty.
6. **Illumination Switch** - This switch changes the front panel back-lighting from BLUE to GREEN to match the vehicle dash or radio back-lighting.
7. **High Pass Output Switch** - This switch controls whether the front and rear outputs are full range or crossed over as high pass outputs to the amplifiers. When set to high pass output the front and rear output crossovers are separately variable from 30 to 400Hz, by using the high pass frequency control knob (#5) on the front panel.

8. **Front Amplifier Output** - These are output jacks for sending the audio signal to the front amplifier.
9. **Rear Amplifier Output** - These are output jacks for sending the audio signal to the rear amplifier.
10. **Subwoofer Amplifier Output** - These are output jacks for sending the audio signal to the subwoofer amplifier.
11. **Source 1 Input** - This is the input for the main source unit.
12. **Source 2 Input** - This is the input for the secondary source unit.

FIGURE 2—REAR PANEL

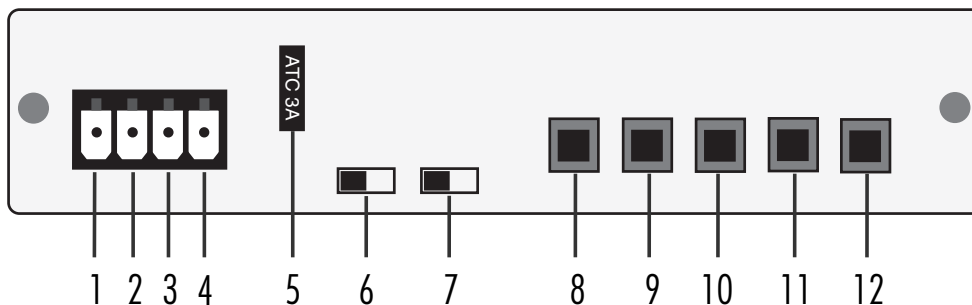

INITIAL SETTINGS

1. Make sure the main source unit is connected to the Source 1 inputs, then adjust the main source units volume to just below maximum.
 2. Adjust the Source 1 input gains (top of unit) to the minimum setting and the 6500 master volume control to the maximum setting.
- NOTE:** If connecting more than one input source to the 6500, use the Source 1 gain controls to match the input level of both sources.
3. Set the filter gains to the flat (center) setting.
 4. Complete all signal and power connection to the 6500.
 5. Turn the system on and increase the gain on the Source 1 inputs until audible distortion can be heard. The system should be very loud at this time.
 6. Reduce the 6500 master volume level and test for well-balanced and linear volume adjustment when using the Source 1 volume control.
 7. When connecting a second source unit to the Source 2 input, the source one input gains (top of unit) may need further adjusting to achieve a close signal level match.

CROSSOVER AND FILTER ADJUSTMENTS

The crossover and filter gain adjustments can be performed two different ways, by using a piece of audio test equipment called an RTA (Real Time Analyzer) or by listening to a familiar piece of music. The RTA is most commonly used to achieve the flattest possible system response in preparation for a sound-off competition. Although an RTA may help in setting a flat system response, it does not allow for your personal listening preferences. When setting the EQ filter and gain controls using a familiar piece of music, adjustments can be made according the way you like the music to sound in relation to the vehicles acoustics and the type of drivers in the system.

1. Set all filter gain controls to their flat setting by adjusting all the filter knobs to the center or 0 setting when they are extended and set to their in position.
2. Set all frequency controls to their flat setting by adjusting all the filter knobs knobs to the flat or 0 setting when they are extended and set to their out position.
3. If using the dedicated subwoofer output, set its gain and frequency control to the center position.
4. Turn on the head unit and play a familiar piece of music as reference material.
5. If the front and rear outputs have been set to high pass by setting the switch on the rear panel to the high pass setting, adjust the front crossover to the lowest possible setting with a minimum of distortion. Repeat for the rear speakers.
6. At this time adjust the subwoofer frequency and volume to match the crossover settings for the satellite speakers. When set properly the bass should not be localized and voices should not be heard through the subwoofers.
7. Adjusting the frequency control knobs out direction from center will change the center frequency and bandwidth parameter for that particular filter. The higher the frequency (clockwise) for a filter the wider bandwidth, the lower the frequency (counter-clockwise) the narrower bandwidth.
8. Once the center frequencies and bandwidth have been adjusted controls have been set, use the filter gains (filter knob's in position) to fine tune the system for differing tastes in music or material.

NOTE: When interfacing Directed class d amplifiers with non-defeatable low-pass crossovers adjust the amplifiers crossover point to its highest frequency setting.

SYSTEM DIAGRAM

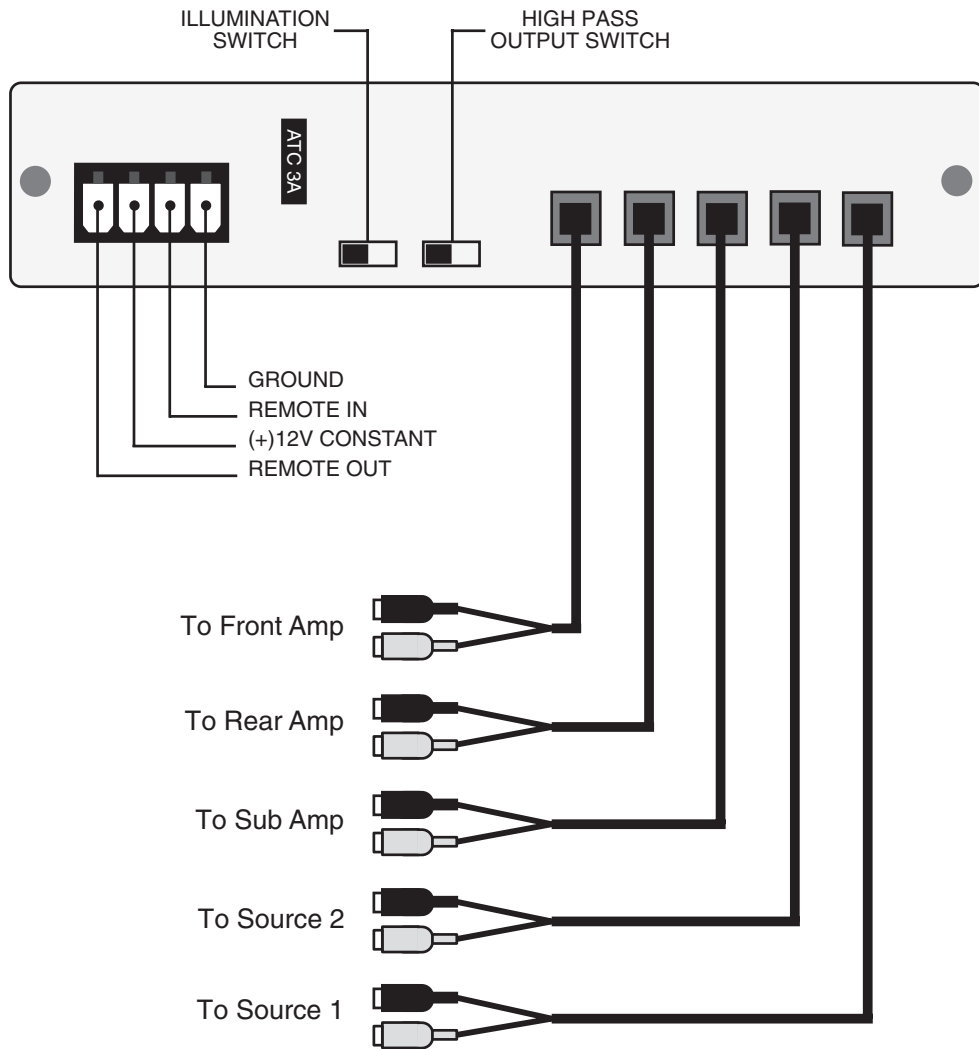

SPECIFICATIONS

Directed model 6500

Filter Parameters	Sub 30-70Hz, Mid-bass 125-250Hz, Low-mid 400-800Hz. Hi-mid 1.5-5kHz Hi 8-20kHz
Boost/Cut	18dB/octave maximum
Filter Bandwidth	Varies with center frequency
Crossover/Range	LP/HP, 12dB/octave, variable 30-400Hz
Signal-to-Noise Ratio	100dB @ 1 volt input
Frequency Response	20Hz-30kHz, +/- 0.5dB
Maximum Output Voltage	6V RMS front/rear outputs 10V RMS subwoofer output
Output Impedance	500 ohm
Gain (all filters set flat)	1V in = 2V (front/rear), 6V (sub)
Total Harmonic Distortion	< 0.006%
Stereo Separation	>75dB @ 1kHz
Input Sensitivity	50mv - 4.0V RMS (fixed inputs) 50mv - 10V RMS (variable input)
Input Impedance	21K ohms
Operating voltage/fuse	11-15V negative ground/3A ATC
Remote Out	500mA @ 11.5V
Size (H x W x D)	1"x 7"x 4-3/4"

Directed[®]
ELECTRONICS, INC.

Directed Electronics, Inc.
Vista, California 92083
www.directed.com

The company behind this system is Directed Electronics, Inc. Since its inception, Directed has had one purpose, to provide customers with the finest vehicle security, car stereo products, rear seat entertainment, and accessories available. The recipient of more than 20 patents in the field of advanced electronic technology, Directed is ISO 9001 registered.

Directed[®] is committed to delivering world-class quality products and services that excite and delight our customers.



Directed is a proud member of



Directed Electronics is an ISO 9001 registered company

Quality Directed products are sold and serviced throughout North America and around the world
Call **800 274 0200** for more information about our products and services